

PRODUCT SPECIFICATION SHEET

UFO 28H Hermetic Fitting



Rev. C1



The UFO 28H downlight fitting allows an airtight seal to be maintained within a display case when using fiber optics.

These fittings are made from aluminum and the air seal is maintained by a series of three o-rings around the flange, eyeball and ferrule. The ferrule is tightened fully onto the fitting and the focus adjustment is made using the trumpet. The further onto the ferrule the trumpet is screwed, the wider the beam. The tight tolerances attained during manufacture help ensure many years of reliable operation.

Chrome finish subject to availability, special orders and extended lead times are required.

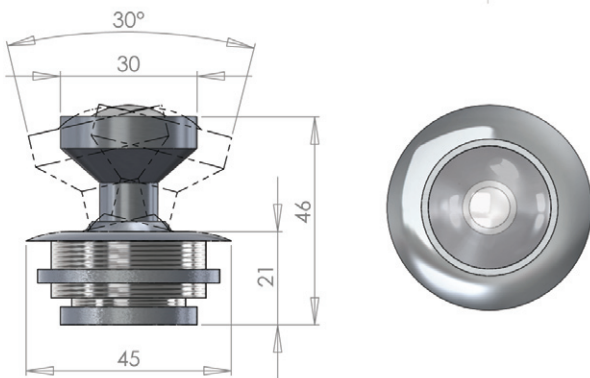

Note that dimensions are shown in mm

TECHNICAL INFORMATION

Lens	26mm (1.02") clear focusing lens
Focus range	40° - 65°
Material	Aluminum
Finishes available	Aluminum, black, white, chrome
Weight	50g (0.11lb)
Mounting hole size	38mm (1.5")
Ferrule size	M10 or 8mm smooth
Min. fiber size	2mm
Max. fiber size	8mm
Flange size	45mm (1.77")

ORDERING CODES

MODEL	MATERIAL		FINISH		FERRULE SIZE	
UFO 28H	Aluminum	ALU	Aluminum	ALU	M10	M10
			Black	BL	8mm	8mm
			White	WH		
			Chrome	CH		
UFO 28H						



Universal Fibre Optics Ltd
Home Place \ Coldstream
TD12 4DT \ UK
+44 (0)1890 883416 \ www.ufo.lighting

Universal Fiber Optic Lighting USA, LLC
1749 Northgate Blvd
Sarasota \ FL34234 \ USA
941-343-8115 \ www.fiberopticlighting.com

UFO Licht GmbH
Andreasstraße 20
93059 Regensburg \ Deutschland
+49 (0)9491 955880 \ www.ufo-licht.de