

# MBL1 Articulated LED Downlight

TECHNICAL SPECIFICATIONS	
LED Type	Oslon Square
LED Power	1W @ 350mA 1.5W @ 500mA*
Power Connection	2 pin Molex
Colour Temperature Options	2700K, 3000K, 4000K
CRI	>95
Luminous Efficacy	98lm/W
Lens Options	13.5° / 19° / 28°
LED Life	>54,000h
Operating Environment	Indoor / dry
Min. Ambient Temperature	-10°C
Max. Ambient Temperature	+40°C
Material	Aluminium
Max Fitting Cable Length (28AWG)	10m (32.8')

**Notes:**  
Maximum cable length is defined by no discernable reduction in light output.

\*500mA variant not for use in USA or Canada



Please read the user guide carefully before installing, operating or performing maintenance on these devices.



Universal Fibre Optics Ltd Home Place Coldstream TD12 4DT UK +44 (0)1890 883416 | www.ufo.lighting

Universal Fiber Optic Lighting USA, LLC 1749 Northgate Blvd Sarasota FL 34234 USA 941-343-8115 | www.fiberopticalighting.com

UFO Licht GmbH Andreasstraße 20 93059 Regensburg Deutschland +49 (0)9491 955880 | www.ufo-licht.de

Problem	Probable Causes	Test & Remedy
Constant Current System System is dead - no light output from LED's	Mains supply off	Check supply and reinstate.
	Loose mains plugs	Check plugs.
	Loose DC output wire or connection	Check all connections.
	Splitter LED channel not terminated	Check all splitter channels have LED fittings plugged in or have continuity jumpers fitted. Plug in LED's and/or jumpers
	Single failed LED	With power ON, carry out one of tests detailed in fault finding guide. Replace faulty LED.
	More than one failed LED	Gradually replace LED plugs with continuity jumpers until LED's light. Do not reduce the number of LED's plugged into the splitter below the driver minimum
Constant Current System Some LED's not working	Driver failed	Check output with DVM. With power ON and no LED's lit, DC voltage output to LED's should be at maximum
	Cable between driver and splitter failed	With power ON and splitter cover removed, put DVM across input to splitter. DC voltage input to splitter (allowing for volt drop in cable) should be at maximum. If no voltage fault find and/or replace cable.
Constant Current System LED's on full illumination - not dimming	Faulty or wrong connection at driver or dimmer control box	Check driver and dimmer connections. Replace/repair as necessary.
	Faulty dimmer potentiometer or damaged dimmer control cable	Remove dimmer control cable from dimmer. Check continuity of cable and dimmer pot. Replace/repair as necessary.
Failed driver	Replace driver.	

## MBL1 Articulated LED Downlight Schematic Showing Driver & Splitter

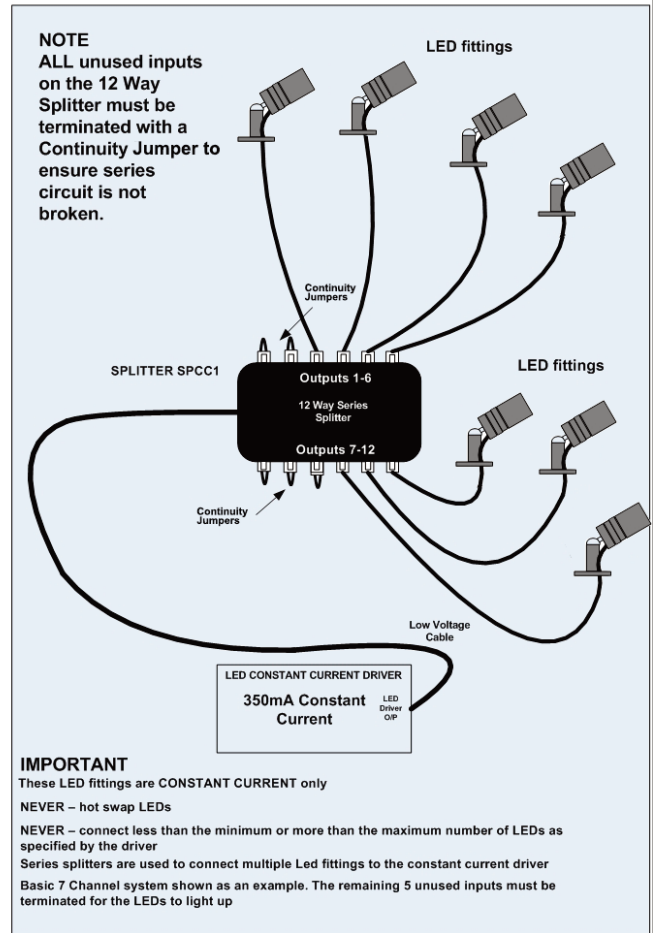

# MBL1 Fixed LED Downlight

1

## Introduction

Thank you for purchasing these low voltage UFO LED fittings.

Please read these instructions fully before installing your LED fittings, connecting your LED fittings to the splitter/driver and before connecting your display system to the electrical mains. Please keep this manual for future reference.

The UFO splitters are supplied with removable continuity jumpers. Retain these jumpers for future use.

Please refer to the specific section within this manual to ensure correct associated splitters/drivers/power supply units are used for your fittings.

These LED fittings are only mains dimmable with an appropriate mains dimmable constant current driver.

These LED fittings operate on a constant current driver low voltage supply. Constant current and constant voltage LEDs cannot be intermixed on the same driver. Please refer to the specific section within this guide for wiring/connection guidance.

# MBL1 Articulated LED Downlight

3

## MBL1 Fitting Guide

MBL1 Downlights are constant current LED fittings.

Before assembly, unpack the shipment and check that all components are included before commencing your installation. It is recommended that the system be planned prior to work commencing to ensure the Series Splitter is centrally located to match LED fitting cable lengths. Fit all MBL1 fittings in place as detailed below.

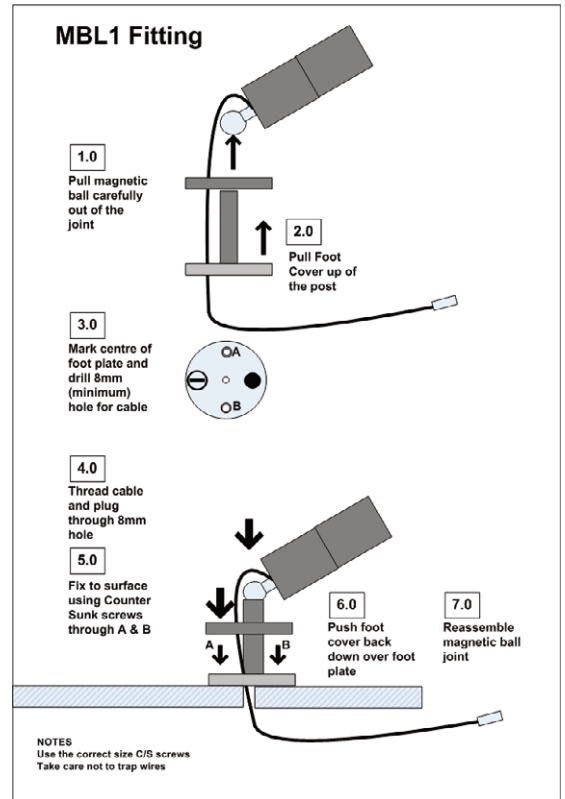

# MBL1 Articulated LED Downlight

2

## Safety Guidelines

**WARNING** – Connecting constant current LED fittings to a driver with excessive minimum voltage output will result in catastrophic damage to the LED devices within these fittings. Always check the minimum output voltage of the driver and ensure that based on 3.2V per LED an adequate number of fittings are connected prior to powering up the system.

**WARNING** – Hot swapping constant current LED fittings to a driver may result in catastrophic damage to the LED devices within these fittings. Always power down the driver before adding a constant current LED fitting.

These LED fittings are suitable for indoor/dry areas and must not be installed in damp or wet conditions.

### IMPORTANT

**THIS PRODUCT MUST BE INSTALLED IN ACCORDANCE WITH THE APPLICABLE INSTALLATION CODE BY A PERSON FAMILIAR WITH THE CONSTRUCTION AND OPERATION OF THE PRODUCT, ITS COMPONENT PARTS AND THE HAZARDS INVOLVED.**

**ELECTRICAL WIRING AND CONNECTION MUST BE CARRIED OUT BY A SUITABLY QUALIFIED PERSON OBSERVING ALL LOCAL AND STATUTORY ELECTRICAL REGULATIONS.**

# MBL1 Articulated LED Downlight

4

## Connections

The fittings are suitable for use with a constant current driver only.

- 350mA or 500mA output (depending on territory)
- Rated Class 2 or LPS
- Approvals UL/CE
- Protection - Short Circuit/Over load/ Over voltage
- Minimum voltage rating not to exceed the number of LED fittings connected
- Number of LED fittings connected not to exceed the Maximum voltage rating

There are 4 electrical connections required before connecting the system to the mains.

1. Connect **ALL** LED fittings to the input channels of the Series Splitter.
2. Make sure **ALL** unused Series Splitter channels have continuity jumpers fitted
3. Connect the Series Splitter directly to the Constant Current Driver.
4. Connect the electrical supply to the driver. Switch on power, the LED fittings will illuminate.

If no light is produced, consult the TROUBLESHOOTING section.